

TAG: JDY-08 Bluetooth LE BLE HM-10 HM-11 AT-09 CC41-A

Original Reference (Chinese) :

- <http://pan.baidu.com/s/1jIdeMDw>
- <http://www.cnledw.com/inter/upload/2016072916504828280.pdf>
- <https://pan.baidu.com/s/1nvAnmeX> (v2.63)

JDY-08 Bluetooth transparent transmission module

(WeChat transparent transmission,
APP pass-through from the main one, iBeacon)

The version number: JDY-08-V2.1

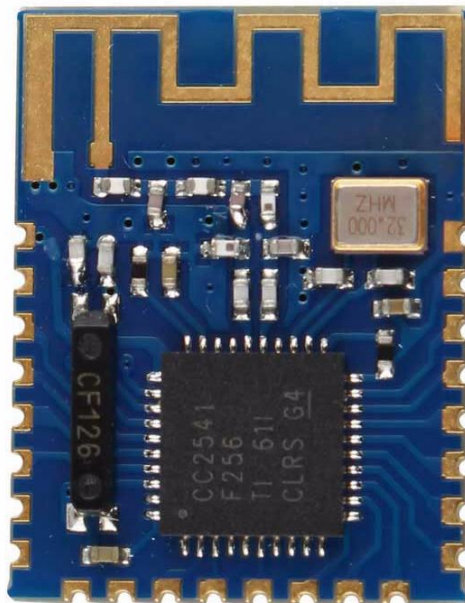

Product Introduction

JDY-08 transparent transmission module is based on the Bluetooth 4.0 protocol standard, the working frequency of 2.4GHZ range, modulation scheme is GFSK, the maximum transmit power of 0db, maximum transmission distance of 80 meters, the use TI CC2541 chip design, allowing users to modify the device name through AT commands service UUID, transmit power, pairing password instructions, convenient to use and flexible.

Quick Start

This is not part of the original datasheet. For experienced in other BLE modules. Written by 1saac_k.

Warning!

- Some functionality may not work: password(pin) authentication and serial tx of JDY-08, ..
- I highly recommend to upgrade firmware v540 of HM-10 (or v2.63 of JDY-08)
 - Ref. - <http://forum.arduino.cc/index.php?topic=393655.0>
 - Ref. - <https://forum.arduino.cc/index.php?topic=432074.0>
 - Best practice is a using Arduino of 3.3v version. In 5v version, you can use a 3.3v power out of arduino and use the logic level converter for digital out (voltage divider using resistors not work).
 - If you not gonna use the level converter, you should connect a 5v for VCC. See a below pic. It just works with some risks.

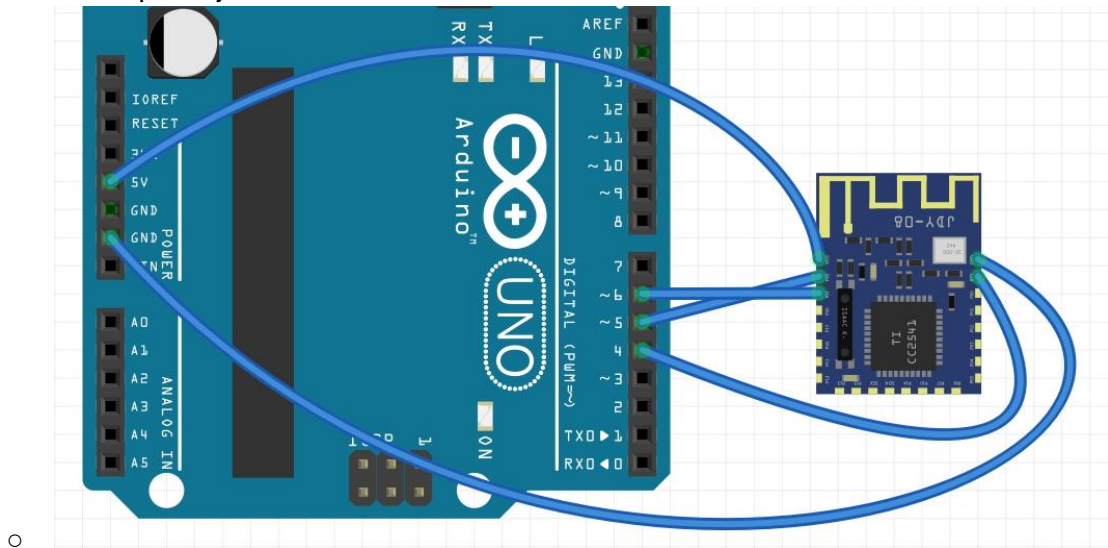

Use it as iBeacon

- Connect power (VCC as 3.3v, GND)

Configuration using AT command

- Connect power, Rx(P02), Tx(P03) and **PWRC(P00)**
- Baud rate is **115200**
- Disconnect Bluetooth before get into AT mode

Connect via Bluetooth and send data

- Connect power and your own pins (but do not connect PWRC)
- Here is example

```
$ sudo hcitool lescan
..
88:4A:EA:45:0A:0B JDY-08
```

```

..
$ gatttool -b 88:4A:EA:45:0A:0B -I
[88:4A:EA:45:0A:0B][LE]> connect
[88:4A:EA:45:0A:0B][LE]> char-desc
..
handle: 0x0018, uuid: 0000ffe1-0000-1000-8000-00805f9b34fb
..
handle: 0x0030, uuid: 0000ffe7-0000-1000-8000-00805f9b34fb
..
[88:4A:EA:45:0A:0B][LE]> char-write-cmd 0x30 62 # Get name
Notification handle = 0x0030 value: 62 4a 44 59 2d 30 38
[88:4A:EA:45:0A:0B][LE]> char-write-cmd 0x18 010203 # Serial TX

```

Common AT command

- AT+NAMETEST - Set name to "TEST" (Default is "JDY-08". Max len is 15)
- AT+PASS1234 - Set password to "1234" (Only valid when AT+ISCEN is 1)
- AT+ISCEN1 - Turn on password authentication (Default is turned off)
- AT+BOUD4 - Set baud rate to 9600 (Default is 19200)
- AT+NEIN1 - Change connection interval 10ms to 100ms (For power saving)

Features

1. Pass-through the WeChat (support AirSync protocol, used in WeChat communication H5 or server manufacturers, including long packet data analysis Transceiver)
2. WeChat control mode (motor speed control, LED light switch control)
3. APP transparent transmission (support Android, IOS data transparent transmission)
4. iBeacon mode (support micro-letter shake agreement with Apple iBeacon agreement)
5. Sensor mode (number of sensors of temperature, humidity and other acquisition applications)
6. Host transparent mode (transparent transmission of data between the application module, to communicate with the host machine from)
7. Host observer mode (sensor applications, indoor location)
8. PWM mode (applied to the motor speed, LED lights dimming)
9. IO mode (used in mobile phones to control relays or LED light off)
10. Indoor room-bit applications (applications to achieve data collection iBeacon range positioning)
11. RTC mode
12. RTC alarm mode: Room settings can be set to control the RTC alarm time IO port, supports two alarm

Electrical Characteristics

Operating mode	status	Electric current
Slave transparent mode	Connect / Not connected / standby	0.8mA/300uA/1uA
Slave broadcast mode (iBeacon, sensor)	Connect / Not connected / standby	0.5mA/300uA/1uA
Host transparent mode	Connect / Not connected / standby	20mA/9mA/1uA
Host mode observer (sensor)	Connect / Not connected / standby	25mA

The above test supply voltage is 3.3v

Dimensions

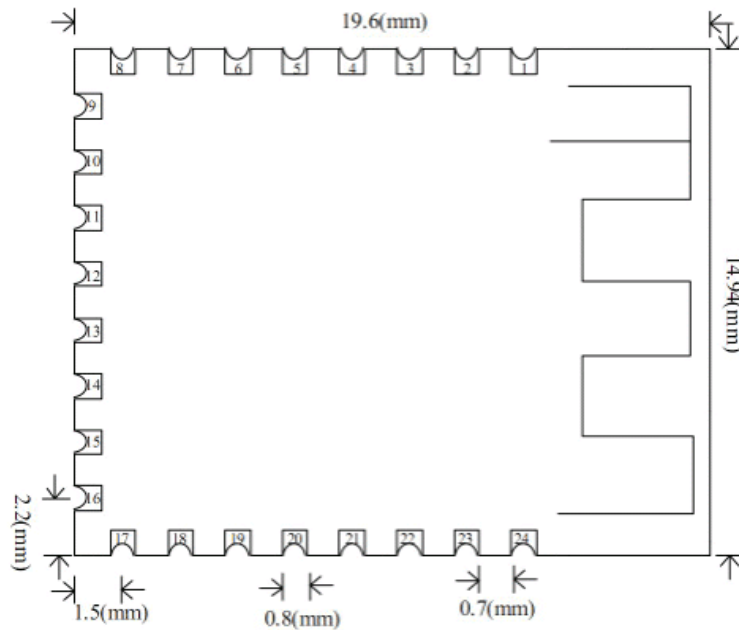

Pin Pitch 1.5mm
 Pin width 0.8mm
 Pin Height 0.6mm

Pin Definitions

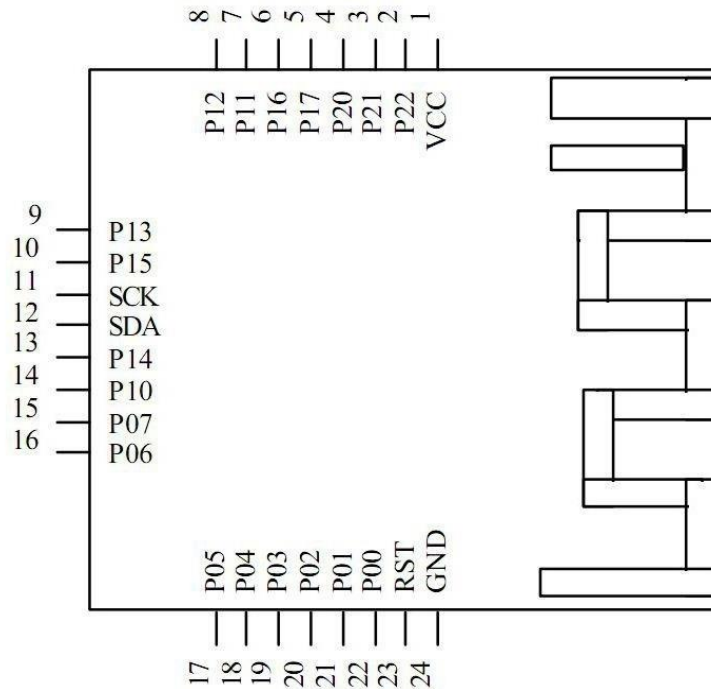

Pin Function Description

Pin	Definition	Features	Description
1	VCC	power supply	Power supply 3V or 3.3V
2	P22/DC	debug clock	
3	P21/DD	debug data	
4	P20		
5	P17		
6	P16	Pin connection status	Active low (low when connected) (master and slave valid)
7	P11	PWM2	PWM2 output pin can be controlled by APP
8	P12	IO1	IO1 output pin can be controlled by APP level
9	P13	IO2	IO2 output pin can be controlled by APP level

10	P15	IO3	IO3 output pin can be controlled by APP level
11	SCK	I2C clock	
12	SDA	I2C data	
13	P14	IO4	IO4 output pin can be controlled by APP level
14	P10	PWM1	PWM1 output pin can be controlled by APP
15	P07	PWM3	PWM3 output pin can be controlled by APP
16	P06	PWM4	PWM4 output pin can be controlled by APP
17	P05	RTC alarm IO	When the RTC timing when IO output low
18	P04	RTC alarm IO	When the RTC timing when IO output low
19	P03	TXD	Serial output, the level is TTL level
20	P02	RXD	Serial input, the level is TTL level
21	P01		
22	P00	PWRC	Wakeup pin. Internal pull-up resistor. Active low. Connect to GND to enter AT command mode.
23	RST	Reset	Hardware reset pin
24	GND	Power Ground	

AT commands

AT command set

No.	Command	Description	Master /Slave	Operation Mode	Default
1	AT+RST	Reset	M/S		
2	AT+BOUD	Serial baud rate setting	M/S		115200
3	AT+HOSTEN	Master and slave settings	M/S		Slave
4	AT+HOST	Read the host status	M		
5	AT+DISC	Disconnect	M		
6	AT+ADVEN	Open the radio	S		Turn On

7	AT+ADVIN	Broadcast interval	S		100ms
8	AT+NEIN	Connection Interval	S		10ms
9	AT+POWR	Transmission power	S		0db
10	AT+NAME	Broadcast name	S		JDY-08
11	AT+MAC	Read the MAC address	M/S		
12	AT+STRUUID	Set the iBeacon UUID (string class Type UUID)	S	iBeacon	WeChat UUID
13	AT+HEXUUID	Set the iBeacon UUID (hexadecimal Type UUID)	S	iBeacon	WeChat UUID
14	AT+MAJOR	Set the iBeacon Major (string class Type Major)	S	iBeacon	10
15	AT+MINOR	Set the iBeacon Minor (string class Type Minor)	S	iBeacon	7
16	AT+VER	Read version number	M/S		JDY-08-2.1
17	AT+VID	Manufacturer ID (For manufacturers can not identify)	S	iBeacon sensor	8899
18	AT+TEMP	Temperature setting	S	iBeacon sensor	0
19	AT+HUMID	Humidity setting	S	iBeacon sensor	0
20	AT+ISCEN	Set whether to open the password connection	S		Turn Off
21	AT+PASS	Connection password	S		1234
22	AT+SVRUUID	Change the service UUID	M/S		FFE0
23	AT+CHRUUID	Change the feature UUID	M/S		FFE1
24	AT+SCAN	The master scans the slave	M	Host passthrough	
25	AT+RSLV	Read from the host to scan to the machine MAC	M	Host passthrough	
26	AT+CONNET	Connects to the MAC of the slave	M	Host passthrough	
27	AT+BAND	Binds the slave MAC	M		
28	AT+GETDCD	Reads the number of slaves scanned by the host	M		
29	AT+GETSTAT	Find the working status of the module	M/S		
30	AT+PWMFRE	Set the PWM frequency	M/S		500HZ
31	AT+PWMOPEN	Turn on the PWM	M/S		shut down
32	AT+PWM1PUS	Set the PWM1 pulse width	M/S		50%
33	AT+PWM2PUS	Set the PWM2 pulse width	M/S		50%
34	AT+PWM3PUS	Set the PWM3 pulse width	M/S		50%
35	AT+PWM4PUS	Set the PWM4 pulse width	M/S		50%
36	AT+RTCDATE	Set the RTC time	M/S		
37	AT+RTCOPEN	Turn on the RTC function	M/S		shut down

38	AT+WXSVR	WeChat H5 communication with the server settings	S	WeChat	H5
----	----------	--	---	--------	----

AT commands Description

- Soft reset
 - Instruction: AT + RST
 - Returns: OK
- Setting the baud rate Note: **The module default baud rate is 115200**
 - Command: AT + BOUD0 means the baud rate is 115200
 - Command: AT + BOUD1 means the baud rate is 57600
 - Command: AT + BOUD2 means the baud rate is 38400
 - Command: AT + BOUD3 means the baud rate is 19200
 - Command: AT + BOUD4 means the baud rate is 9600
 - Returns: OK
- Set the module operating mode
 - Command: AT + HOSTEN0 means to set the transparent mode (APP, WeChat)
 - Command: AT + HOSTEN1 indicates that the host transparent mode is set
 - Instruction: AT + HOSTEN2 indicates that the host (indoor positioning, sensor) observer mode is set
 - Command: AT + HOSTEN3 Indicates that the slave (iBeacon, sensor) mode is set
 - Returns: OK
- Disconnect
 - Instruction: AT + DISC Indicates a disconnection
 - Returns: OK
- Open the radio
 - Instruction: AT + ADVEN0 indicates that the broadcast is stopped
 - Instruction: AT + ADVEN1 indicates that the broadcast is turned on and does not turn on after power-up
 - Instruction: AT + ADVEN2 indicates that the broadcast is turned on and turned on after power-up
 - Returns: OK
- Broadcast interval
 - Instruction: AT + ADVIN0 means to set the broadcast interval to: 100ms
 - Instruction: AT + ADVIN1 means to set the broadcast interval to: 500ms
 - Instruction: AT + ADVIN2 means to set the broadcast interval to: 750ms
 - Instruction: AT + ADVIN3 means to set the broadcast interval to: 1000ms
 - Instruction: AT + ADVIN4 means to set the broadcast interval to: 2000ms
 - Instruction: AT + ADVIN5 means to set the broadcast interval to: 4000ms
 - Instruction: AT + ADVIN6 means to set the broadcast interval to: 8000ms
 - Returns: OK
- Connection Interval
 - Instruction: AT + NEIN0 connection is 10ms

- Command: AT + NEIN1 connection is 100ms
 - Command: AT + NEIN2 connection is 500ms
 - Returns: OK
- Transmission power
 - Instruction: AT + POWR0 that set the transmit power to 4db (in CC2541 module set to 0db)
 - Command: AT + POWR1 means to set the transmit power to 0db
 - Command: AT + POWR2 that set the transmit power -6db
 - Command: AT + POWR3 means to set the transmit power to -23db
 - Returns: OK
 - Instruction: The AT + POWR instruction is followed by a read without parameters
 - Returns: POWR0db indicates that the module transmit power is: 0db
- Set the broadcast name
 - Instruction: AT + NAMEJDY-08 That set the broadcast name: JDY-08
 - Returns: OK
 - Command: AT + NAME The instruction is followed by a parameter without a read
 - Returns: JDY-08 Indicates that the module broadcast is named JDY-08
- Reads the MAC address
 - Instruction: AT + MAC
 - Returns: MAC: 001830EA0662 Indicates that the MAC address is: 001830EA0662
- Set the iBeacon UUID
 - The string type UUID is set, UUID is: FDA50693A4E24FB1AFCFC6EB07647825
 - Command: AT + STRUUIDFDA50693A4E24FB1AFCFC6EB07647825
 - Returns: OK
 - Set as UUID in hexadecimal, UUID is: FDA50693A4E24FB1AFCFC6EB07647825
 - Directive: 41542b4845585554944FDA50693A4E24FB1AFCFC6EB07647825
 - Returns: OK
 - Instruction: The AT + STRUUID instruction is followed by a read without parameters
 - Returns: UUID: FDA50693A4E24FB1AFCFC6EB07647825
- Reads the UUID in hexadecimal
 - Command: AT + HEXUUID
 - Return: 555549443AFDA50693A4E24FB1AFCFC6EB07647825
- Set iBeacon Major
 - Command: AT + MAJOR000A Indicates that Major is set to 10
 - Returns: OK
 - Instruction: The AT + MAJOR instruction is followed by a read without parameters
 - Returns: 4D414A4F523A000A Returns the data in hexadecimal format Major: 0x000a
- Set iBeacon Minor
 - Command: AT + MINOR0007 means to set Minor to 7

- Returns: OK
 - Command: The AT + MINOR instruction is followed by a read without parameters
 - Returns: 4D494E4F523A0007 Returns the data in hexadecimal format Minor: 0x0007
- Read the module version number
 - Command: AT + VER instruction is not behind the parameters that read
 - Back to: JDY-08-V2.1
- Set the factory identification code
 - Command: AT + VID1122 means to set the factory identification code to 1122
 - Returns: OK
 - Command: AT + VID Read the factory identification code
 - Returns: VID: 1122
- Set the temperature value
 - Command: AT + TEMP32 means the setting temperature is 32 degrees
 - Returns: OK
- Set the humidity value
 - Command: AT + HUMID11 means that the relative humidity is set to 11%
 - Returns: OK
- Set whether to open the password connection
 - Instruction: AT + IScen1 indicates that the password connection is open
 - Instruction: AT + IScen0 indicates that the password connection is closed
 - Returns: OK
- Set the connection password
 - Command: AT + PASS1234 means to set the connection password: 1234
Password length can only be 4 bits
 - Returns: OK
 - Command: AT + PASS indicates to read the connection password
 - Returns: PSS: 1234
- Change the service UUID
 - Instruction: AT + SVRUUIDFFF0 means set service UUID is: 0xFFFF0
 - Returns: OK
 - Command: AT + SVRUUID Indicates the read service UUID
 - Returns: SRUUID: FFF0
- Change the pass-through feature UUID
 - Command: AT + CHRUUIDFFF1 Indicates that the feature UUID is set to 0xFFFF1
 - Returns: OK
 - instruction: AT + CHRUUID Indicates read feature UUID
 - Returns: SRUUID: FFF1
- Host scan
 - Command: AT + SCAN1 Indicates that the master starts scanning the slave
 - Command: AT + SCAN0 Indicates that the master stops scanning the slave
 - Returns: OK
- The host reads the number of slaves scanned

- Command: AT + GETDCD
- Returns: DEV: 1 indicates that the host has scanned a device and can scan up to 8 devices
- The master reads the scanned slave MAC address
 - Instruction: AT + RSLV0 means the host reads the MAC address of list 0, and can read up to 8 lists of addresses
 - Returns: MAC: 001830EA0662
- The address of the list to which the host connection is scanned
 - Command: AT + CONNET0 Indicates the MAC address of host connection list 0
 - Returns: OK
- The MAC address that the host binds to
 - Command: AT + BAND0 Indicates the MAC address of Host Binding List 0
 - Returns: OK
 - Instruction: AT + BAND001830EA0662 Indicates that the host binding specifies the MAC address: 001830EA0662
 - Returns: OK
 - Command: AT + BAND Indicates that the bound MAC address is read
 - Returns: MAC: 001830EA0662
- Read the working status of the module
 - Command: AT + GETSTAT
 - The following is the return status of each operating mode
 - 1: Slave transmission mode
 - Returns: STS: 0111

The stunning part corresponds to the left function		
Bits	Features	Description
4 (MSB)	Operating mode	0: passthrough mode
3	Connection Status	1: connected, 0: disconnected
2	The broadcast opens	1: enabled, 0: disabled
1 (LSB)	Connect using password	1: enabled: 0: disabled

- 2: Host transparent mode
 - Returns: STS: 10
 - 1: Indicates the host transparent transmission mode
 - 0: Connected, 1: Connected
- 3: Slave iBeacon mode
 - Returns: STS: 301
 - 3: Indicates the iBacon mode
 - 0: Not connected, 1: Connected
 - 1: Indicates that the broadcast is on, and 0 means that the broadcast is not turned on
- 4: Host observer mode

- Returns: STS: 2
 - 2: Indicates the host observer mode
- PWM frequency setting
 - Command: AT + PWMFRE260 means to set the PWM frequency to 260HZ
 - Returns: OK
 - Command: AT + PWMFRE read PWM frequency
- Turn on the PWM function
 - Command: AT + PWMOPEN1 Indicates that the PWM is turned on
 - Command: AT + PWMOPEN0 means to turn off PWM
 - Returns: OK
 - Instruction: AT + PWMOPEN Read the PWM operating state
 - Returns: PWMOPEN: 1
 - 1 for development, 0 for off
- Set the PWM1 pulse width
 - Instruction: AT + PWM1PUS50 means to set the pulse width of PWM1 to 50%
 - Returns: OK
- Set the PWM2 pulse width
 - Instruction: AT + PWM2PUS10 means to set the pulse width of PWM2 to 10%
 - Returns: OK
- Set the PWM3 pulse width
 - Instruction: AT + PWM3PUS90 means setting pulse width of PWM3 to 90%
 - Returns: OK
- Set the PWM4 pulse width
 - Instruction: AT + PWM4PUS80 means setting pulse width of PWM4 to 80%
 - Returns: OK
- Set the RTC time
 - Instruction: AT + RTCDATE2014-12-05,12: 07: 08 Indicates that the RTC time is set to December 5, 2014, 12: 7: 8
 - Returns: OK
 - Command: AT + RTCDATE Read RTC time
 - Return: AT + RTCDATE14-12-05, 12: 07: 09 Indicates that the read RTC time is December 5, 2014, 12:7:9
- RTC function switch
 - Command: AT + RTCOPEN0 means to turn off the RTC
 - Command: AT + RTCOPEN1 Indicates that the RTC is on
 - Command: AT + RTCOPEN2 Indicates that the RTC is turned on and turned on
 - Returns: OK
- WeChat H5 or server selection
 - Command: AT + WXSVR0 Indicates communication with WeChat H5
 - Instruction: AT + WXSVR1 Indicates communication with the factory server via WeChat
 - Returns: OK
 - Command: AT + WXSVR Read status

- Returns: WXSVR: 0 Indicates that the return status of 0 represents H5, 1 represents the factory manufacturer server

Mobile terminal command (GATT)

UUID list

- Services UUID: 0XFFE0 (user can change the UUID)
- Characterized UUID: 0XFFE1 (for transparent transmission. users can change the UUID)
- Characterized UUID: 0XFFE2 (Set for iBeacon UUID)
- Characterized UUID: 0XFFE3 (For iBeacon Major settings)
- Characterized UUID: 0XFFE4 (For iBeacon Minor settings)
- Characterized UUID: 0XFFE5 (For broadcast interval)
- Characterized UUID: 0XFFE6 (For password feature set)
- Characterized UUID: 0XFFE7 (Device name settings)
- Characterized UUID: 0XFFE8 (Output function setting for IO)
- Characterized UUID: 0XFFE9 (For the PWM function setting)
- Characterized UUID: 0XFFEA (For Other function settings)
- Characterized UUID: 0XFFEB (For transmission power setting)
- Characterized UUID: 0XFFEC (For the RTC feature set)

WeChat UUID list

- WeChat UUID standard is not described here, the user directly

APP command specification

1) APP transparent transmission (use features UUID: 0XFFE1)

0XFFE1 to APP transparent transmission characteristics UUID (used in iOS or Android phone APP transparent transmission)

2) iBeacon UUID set and read (using feature UUID: 0XFFE2)

Setting UUID command format: 0X11 + 16-bit hexadecimal UUID

Instruction: 0X11FDA50693A4E24FB1AFCFC6EB07647825

Read UUID command format: 0X12

Instruction: 0X12

Returns: 0X12FDA50693A4E24FB1AFCFC6EB07647825

0X12 for the command header, FDA50693A4E24FB1AFCFC6EB07647820 the UUID

3) iBeacon Major set and read (using feature UUID: 0XFFE3)

Major instruction set format: 0X21 + 2 digit hexadecimal Major

Instruction: 0X21000A Description Major hexadecimal 0X000A

Major read instruction format: 0X22

Returns: 0X22000A

Description 0X22 header for the command, 0X000A hexadecimal Major

4) iBeacon Minor setting and reading (Use features UUID: 0XFFE4)

Set the broadcast interval instruction format: 0X41 + 2 digit hexadecimal Minor

Instruction: 0X320007 set Minor expressed in hexadecimal 0X0007

Instruction: 0X32 represents a hexadecimal value read Minor

Returns: 0X320007 Description 0X32 is the command head, 0X0007 in hexadecimal Minor

5) Broadcast interval and reading (Use features UUID: 0XFFE5)

Set the broadcast interval instruction format: 0X41 + 1 digit hexadecimal data

Instruction: 0X4100 indicates set the broadcast interval: 100ms

Instruction: 0X42 represents read the broadcast interval

Returns: 0X4200 0X42 described as a command head, 0X00 indicates the broadcast interval: 100ms

APP send commands	Broadcast interval
0X4200	100ms
0X4201	500ms
0X4202	750ms
0X4203	1000ms
0X4204	2000ms
0X4205	4000ms
0X4206	8000ms

6) Setup and connection password to read (Use features UUID: 0XFFE6)

Set the connection password Format: 0X51 +4 digit hexadecimal code

Instruction: 0X5131323334 represented set password: 1234

Instruction: 0X52 indicates a read instruction password

Returns: 0X5231323334 Description 0X52 is the command head, 0X31323334 the password is: 1234

7) Broadcast name setting and reading (Use features UUID: 0XFFE7)

Set the broadcast name Instruction format: 0X61 + broadcast name (broadcast name no longer than 12 bytes)

Instruction: 0X614A44592D3038 set the broadcast name indicates: JDY-08

Instruction: 0X62 represents read broadcast name

Returns: 0X624A44592D3038 Description 0X62 is the command head, 4A44592D3038 are broadcast entitled: JDY-08

8) APP control IO port (Use features UUID: 0XFFE8)

IO port number	APP send commands	Features
IO1	0xF100	IO1 Output low
	0xF101	IO1 Output high
IO2	0xF200	IO2 Output low
	0xF201	IO2 Output high
IO3	0xF300	IO3 Output low
	0xF301	IO3 Output high
IO4	0xF400	IO4 Output low
	0xF401	IO4 Output high

Instruction: 0xF101 expressed high set IO1

9) APP PWM control switch (using a feature UUID: 0XFFD9)

Features	APP send commands	return
PWM Close	0XA100	no
PWM Open	0XA101	no
PWM switch boot	0XA102	no
PWM frequency setting (frequency range 50-4KHZ)		
PWM frequency is set to 1000HZ	0XA203E8	no
PWM Duty setting (range 0-99%)		
PWM1 temporary duty ratio set to 10%	0XA30A	no
PWM2 temporary duty ratio set to 50%	0XA432	no
PWM3 temporary duty ratio set to 90%	0XA55A	no
PWM4 temporary duty ratio set to 30%	0XA61E	no
Read PWM state		
Read PWM switching state	0XA8	0XA831 indicates PWM open 0XA830 indicates PWM off
Read PWM frequency	0XA9	0XA903E8 represents the frequency of 1000HZ
Read PWM1 temporary duty ratio	0XAA	0XAA0A represents temporary duty ratio of 10%
Read PWM2 temporary duty ratio	0XAB	0XAB32 represents temporary duty ratio of 50%
Read PWM3 temporary duty ratio	0XAC	0XAC5A represents temporary duty ratio of 90%
Read PWM4 temporary duty ratio	0XAD	0XAD1E represents temporary duty ratio of 30%

10) APP controls Other (use features UUID: 0XFFEA)

Instruction: 0X0101 indicates reset module

Instruction: 0X0102 indicates Bluetooth connection (this feature is only used in slave mode)

11) APP transmit power control (using a feature UUID: 0XFFEB)

Transmit power	APP send commands	Remark
4db	0XC100	Represents the transmit power is set to 4db CC2541 modules: 0db
0db	0XC101	Represents the transmit power is set to 0db
-6db	0XC102	Represents the transmit power is set to -6db
-23db	0XC103	Represents the transmit power is set to -23db
Read transmit power		
Read transmit power	0XC2	Back 0XC201 represents transmit power: 0db

12) APP Control RTC (Use features UUID: 0XFFEC)

Features	APP send commands	return
RTC Off	0XB100	no
RTC On	0XB101	no
RTC apart and start-up	0XB102	no
Set the RTC time to: 15 year, 5 month, 7 day, 9 hour, 9 minutes	0XB20F0507090900	
Read RTC time	0XB3	0XB30F0507090900 It represents 15 year, 5 month, 7 day, 9 hour, 9 minutes

Schematics

Debug board schematics

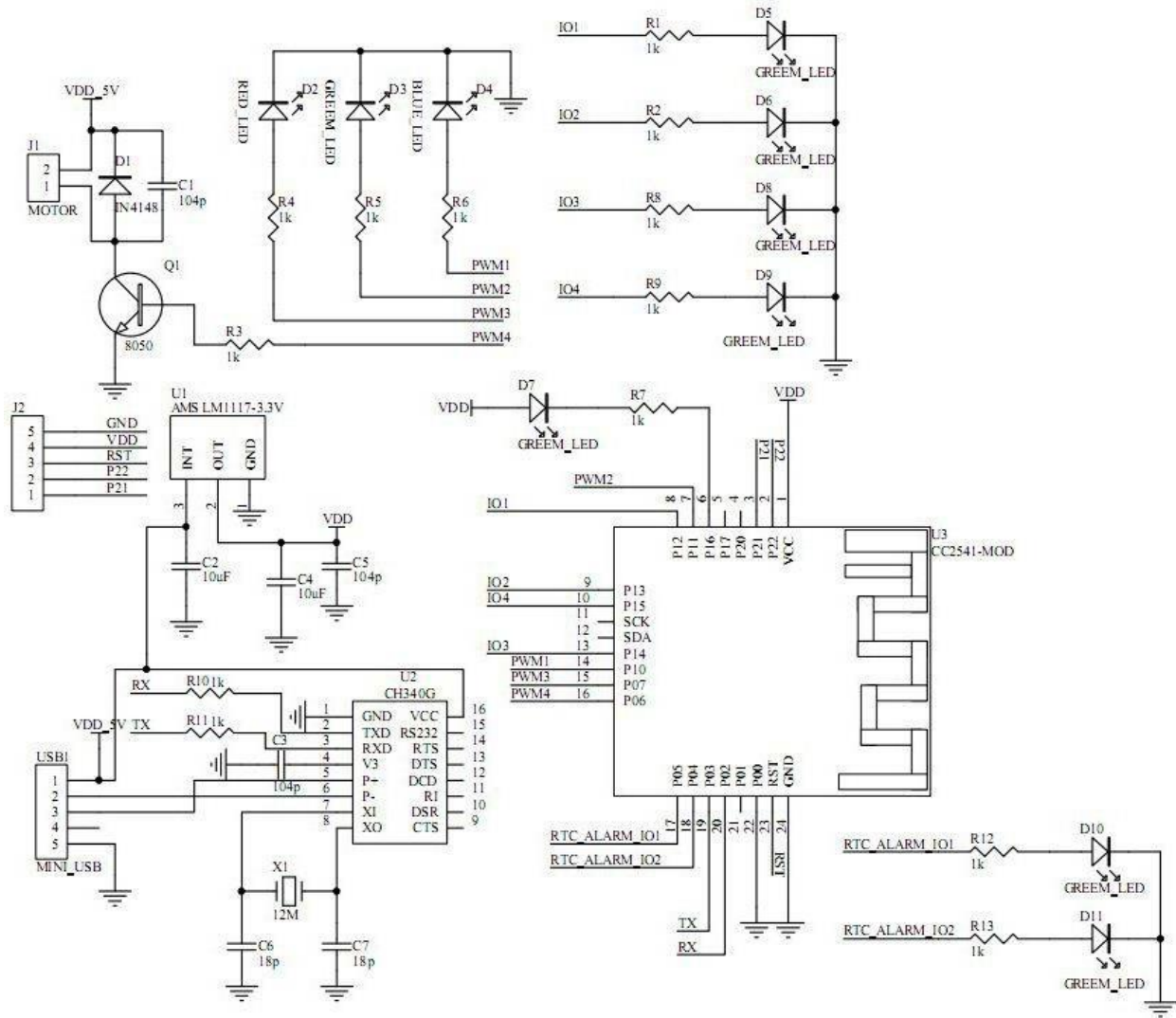

IO control relay or wiring diagram

Many control applications can be applied to electronic locks, light switches or relays (High and low switch control)

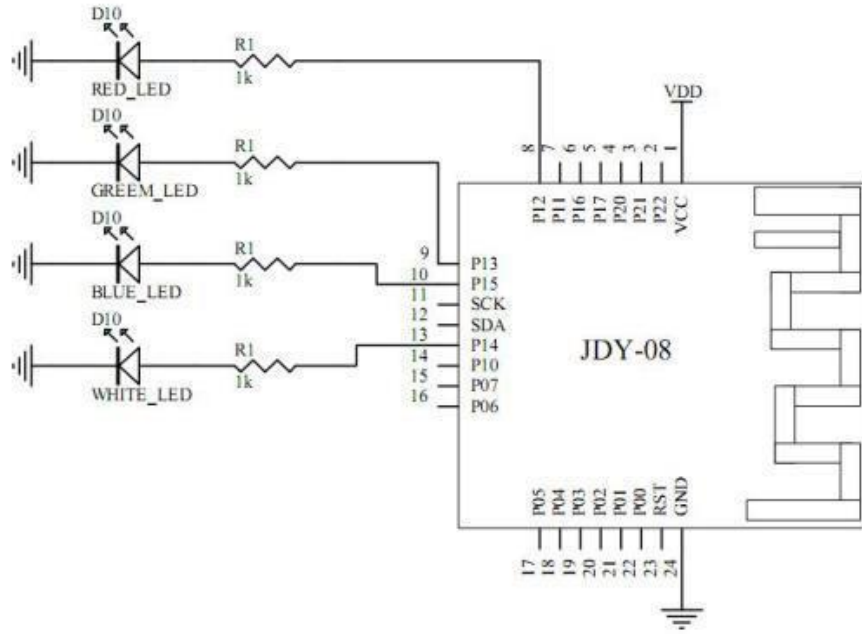

PWM wiring diagram

It can be applied to motor speed, LED brightness control (PWM pulse width modulation)

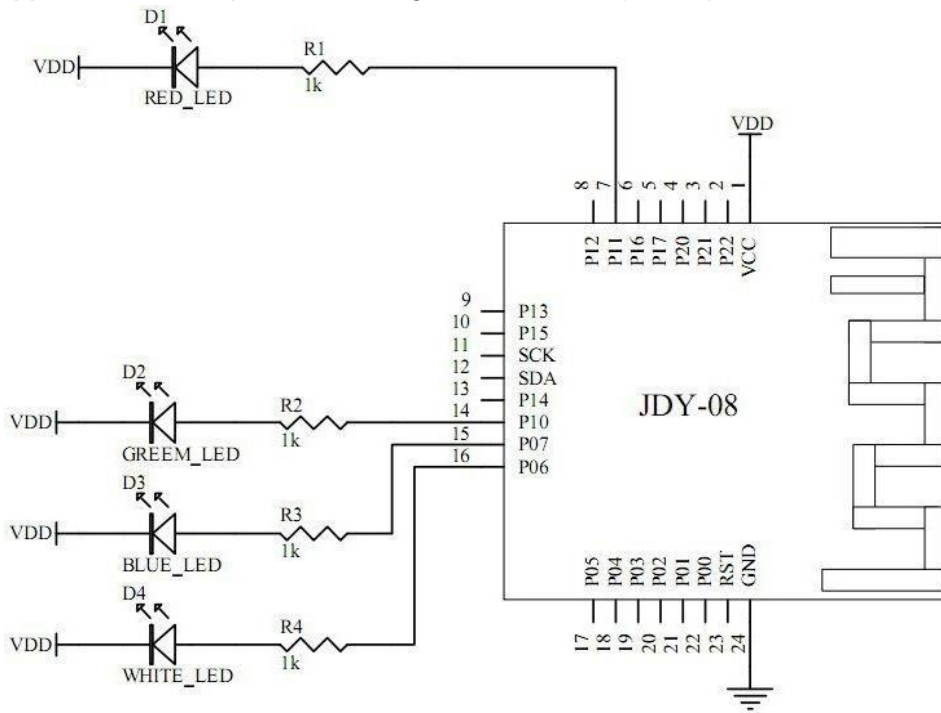

iBeacon wiring diagram

Under iBeacon mode corresponding to the sensor, micro-letter shake, indoor positioning

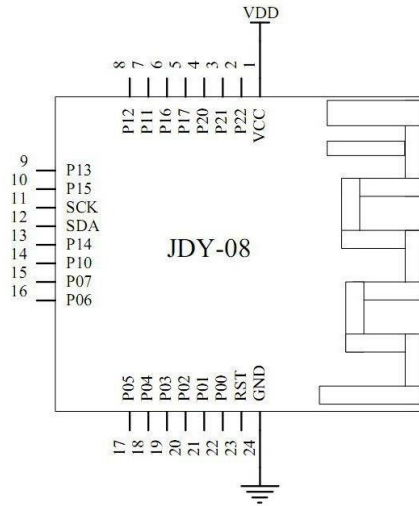

APP WeChat or transparent transmission and MCU wiring diagram

Data communication applications used in blood pressure, heart rate, a pedometer, electronic scales and other products

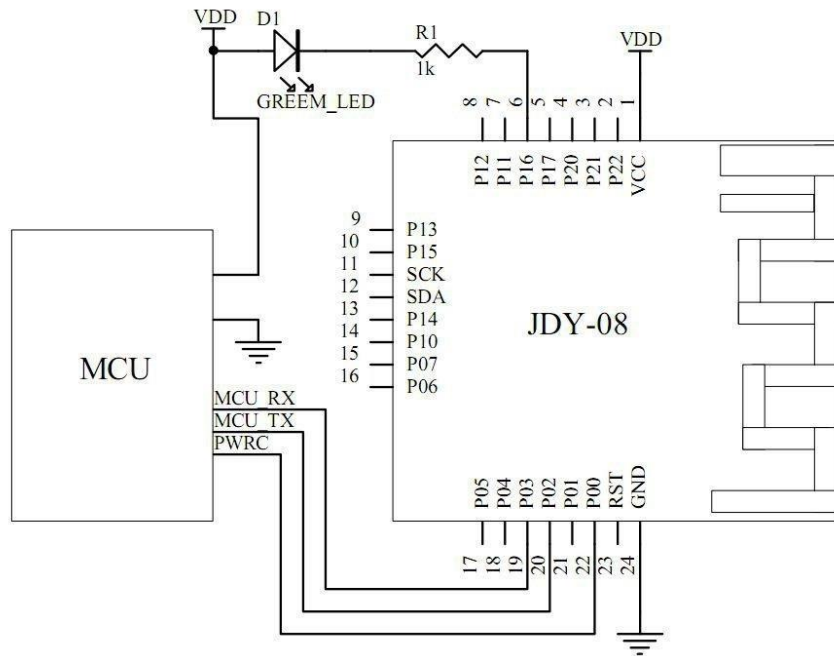

Indoor positioning sensor or wiring diagram mode

Used in indoor positioning, alarms, door switches, electronic meter, attendance attendance, agro remote temperature monitoring

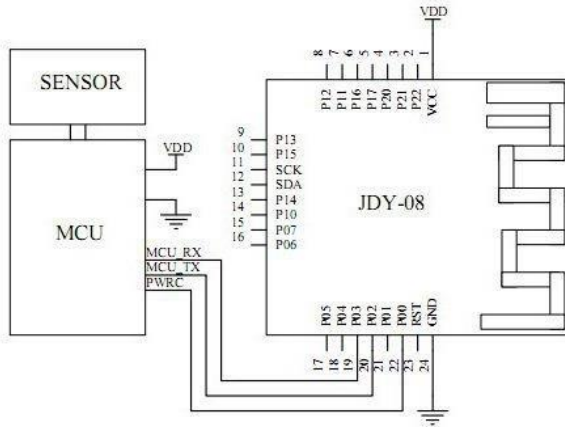

iBeacon mode

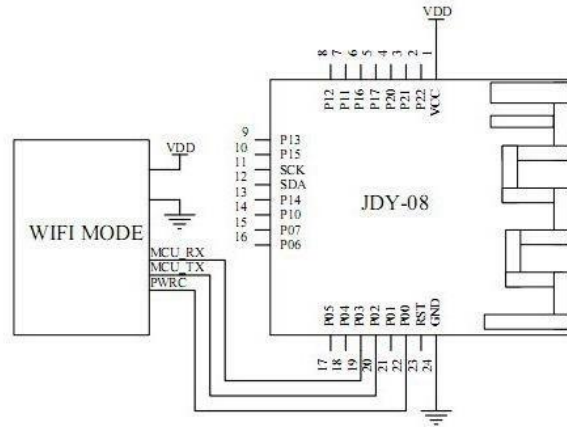

Host Observer pattern

Host sensor receiving function instructions

Connect the serial port (RXD, TXD) of the USB serial or MCU to the module, and connect the PWRC pin of the module to the power supply (VCC, GND) of the module when sending commands using the serial port. The supply voltage is 3.3V or 3V.

According to the above connection line, began to talk about the AT command operation.

Step 1: Configure the module as a host observer

Send via serial port: AT + HOSTEN2 Returns: OK

Step 2: Let the module restart

Send via serial port: AT + RST means reset

Through the above settings, the module has been configured for the host observer mode, then start the host to receive the data from the sensor, the host serial port to receive the sensor data format is as follows.

Payload: head + 6(bytes)MAC + 1(byte)RSSI + 2(bytes)Major + 2(bytes)Minor + 2(bytes)VID + 1(byte) TEMP + 1(byte) HUMID + 1(bytes)BATT

The user can identify their own VID sensor data, and then distinguish each sensor by MAC address.

Note: The data received by the host MAJOR, MINOR, VID, TEMP, HUMID correspond to the data sent by the AT command in the slave sensor mode

AT+MAJOR000A

AT+MINOR0007

AT+VID6677

AT+TEMP44

AT+TEMP44

How to replace the previous Bluetooth transparent module

If your product before using the BLE transparent module, now want to use JDY-8 to replace your previous module, your APP does not need to make any changes, you only need to change our Bluetooth module UUID, you can own To change, you can also let us factory configured to you.

Before you use the transparent module of the service UUID 0XFFF0, features UUID 0XFFF1 words, you only need to send these two commands to change the service UUID and feature UUID of our module.

Send via serial port:

AT + SVRUUIDFFF0	Returns: OK
AT + CHRUUIDFFF1	Returns: OK

You send the above two commands and return OK, that has been configured to complete your configuration is complete, the configuration parameters will be saved power, the next power-on does not need to reconfigure, so that you can directly use our module to connect Your APP out.

iBeacon configuration instructions

JDY-08 module factory default configuration for the transparent function, the general default shipping are shipped through the function, such as the need to configure the iBeacon function, the customer must be with the customer before buying instructions or notes. Because the module is a multi-function module, customers can also configure their own after the purchase of the relevant functional model. This chapter only talk about iBeacon AT command configuration.

Connect the serial port (RXD, TXD) of the USB serial or MCU to the module, and connect the PWRC pin of the module to the power supply (VCC, GND) of the module when sending commands using the serial port. , The supply voltage is 3.3V or 3V.

According to the above connection line, began to talk about the AT command operation

- Step 1: Configure the module as an iBeacon mode command
Send via serial port: AT+HOSTEN3 Returns: OK
- Step 2: Let the module restart
Send via serial port: AT+RST means reset
- Step 3: Change the UBID of iBeacon to (FDA50693A4E24FB1AFCFC6EB07647825)
Send via serial port: AT+STRUUIDFDA50693A4E24FB1AFCFC6EB07647825
Return: OK
- Step 4: Change the Major value of iBeacon to (10)
Send via serial port: AT+MAJOR000A returns OK
- Step 5: Change the minor value of iBeacon to (7)
Send via serial port: AT+MINOR0007 Returns OK

If the user needs to judge their own equipment in the APP, please configure the factory ID number Bluetooth device to determine their own Bluetooth devices UUID and device name, etc. to determine, but these may exist the same, because our standard Module Bluetooth UUID are the same, in order to prevent the identification of the existence of the same factory equipment, we have added a factory ID function for APP to identify their own equipment,

Configure the factory ID to be 65330 (0x1985).

- Send via serial port: AT + VID1985 Returns: OK

User configuration, you can identify their own equipment through the APP, so that their own equipment to ensure that only their own APP can be searched.

Sensor function configuration instructions

JDY-08 module factory default configuration for the transparent function, the general default shipping are shipped through the function, such as the need to configure the sensor function, the customer must be with the customer service before buying instructions or notes. As the module is a multi-functional module, customers can also configure their own after the purchase of the relevant functional model, this chapter only talk about the sensor function AT command configuration.

Connect the serial port (RXD, TXD) of the USB serial or MCU to the module, and connect the PWRC pin of the module to the power supply (VCC, GND) of the module when sending commands using the serial port. , The supply voltage is 3.3V or 3V.

According to the above connection line, began to talk about AT command operation.

- Step 1: Configure the module to iBeacon mode
Note that the sensor function is only applied in the iBeacon mode.
So you need to configure the iBeacon mode.
Send via serial port: AT+HOSTEN3 Returns: OK
- Step 2: Let the module restart
Send via serial port: AT+RST means reset
- Step 3: Set the temperature to 33 degrees
Send via serial port: AT+TEMP33 Returns: OK
- Step 4: Set the humidity value to 11%
Send via serial port: AT+HUMID11 Returns: OK

Since the sensor function is based on the iBeacon application, if you have a large number of sensors, the above two sensor commands can not meet your application, you can use the iBeacon related instructions to transmit your sensor data.

AT+STRUUID + 32-bit string length, please note that this 32-bit data format: Hexadecimal string
AT+MAJOR + 4-bit string length, the string format: hexadecimal string
AT+MINOR + 4-bit string length, string format: hexadecimal string

If the user needs to judge their own equipment on the APP, please configure the factory ID number.

General Bluetooth to determine their own equipment through the Bluetooth service UUID and device name, etc. to determine, but these may exist the same, because our standard module Bluetooth UUID are the same, in order to prevent the identification of the same equipment

manufacturers, we Has added the manufacturer ID function for the APP to identify their own equipment,

The factory ID is 65330 (0x1985).

- Send via serial port: AT + VID1985 Returns: OK

User configuration, you can identify their own equipment through the APP, so that their own equipment to ensure that only their own APP can be searched

This makes the sensor where the advantages?

The traditional approach is to take the phone to your user's sensor signal range, the use of mobile phone APP to connect your sensor, you can read your sensor data, so it is in trouble, simply can not meet the requirements of users, because **This is too complicated, the user uses our way to do sensor applications, the user only need to find the APP can see the sensor data, the phone does not need to connect with the sensor, the phone can display the sensor data.**

Using Host Mode

This only introduces the use of the host, because the default is transparent mode from the machine master-slave Bluetooth module communication refers to two Bluetooth modules communicate with each other, one for the host, a slave, they communicate with each other, the first module for the slave module, the second module is the host module.

The first step is to power up the master and slave modules and the module serial port and USB serial or MCU serial port connection, pay attention to the need to cross the serial line, connect the AT command to start debugging.

The second step will be the first module from the machine to open the radio, the default is to open the broadcast from the machine, but also by sending AT + ADVEN1 to open the broadcast.

Step 3: Set the commands of the main module

- 1) Set the module to host transparent mode, return OK to complete the setup
 - Send command: AT + HOSTEN1
 - Returns OK
- 2) Set the module to restart
 - Send: AT + RST
- 3) Scan the surrounding BLE command
 - Send: AT + SCAN1
 - Returns OK
- 4) Read the number of BLEs scanned (up to 8 slaves)
 - AT + GETDCD returns DEV: 1 means scanning to a device
- 5) Read the slave MAC address of the scan list (0-7)
 - Send: AT + RSLV0
 - Returns: MAC: e3435480
- 6) Connection scan list 0 device (0-7)
 - Send: AT + CONNET0
- 7) Send the command to find out whether it is connected with the slave
 - Send: AT + GETSTAT
 - Returns: STS: 11 Indicates that the connection has been made
- 8) The hardware judges whether it has been connected with the slave
 - Module 6 pin for the connection status pin, the connection is successful for the low, not connected to high
- 9) host and slave connection is successful, you can transparently transfer data

WeChat through the use of function

Module factory default configuration for the transparent configuration, support for Android, IOS APP transparent data transmission, and micro-H5 or factory server data transparently, if you need more than transparent function, you receive the module, then the module Power, send data in the serial port before the PWRC pin to ground, so that the module wake-up, through the serial port can transparently transfer data.

This chapter only tells about the use of micro-messaging.

In this first need to explain, because for the WeChat, the MAC address of each module is very important, we sell each module, we can provide the MAC address of the Excel table to the customer, the customer can also AT command to find the module Of the MAC address, the following began to talk about WeChat and module use.

We have to provide customers with WeChat through the test platform, please pay attention to our public number, "JDY-8" menu can enter.

Here we talk about customers using their own WeChat platform to connect our modules.

- Step 1: The device is authorized
 - The MAC address and device name of the device must be filled in and authorized in the JSON format
- Step 2: Bind the device
 - Please bind the equipment you have authorized the device name,
- The third step:
 - WeChat is generally the default is authorized and bound device, the WeChat side will automatically default to connect with the Bluetooth module, when the connection can be H5 or server data communication