

BIGTREETECH

SKR V1.4

Motherboard Operating instruction

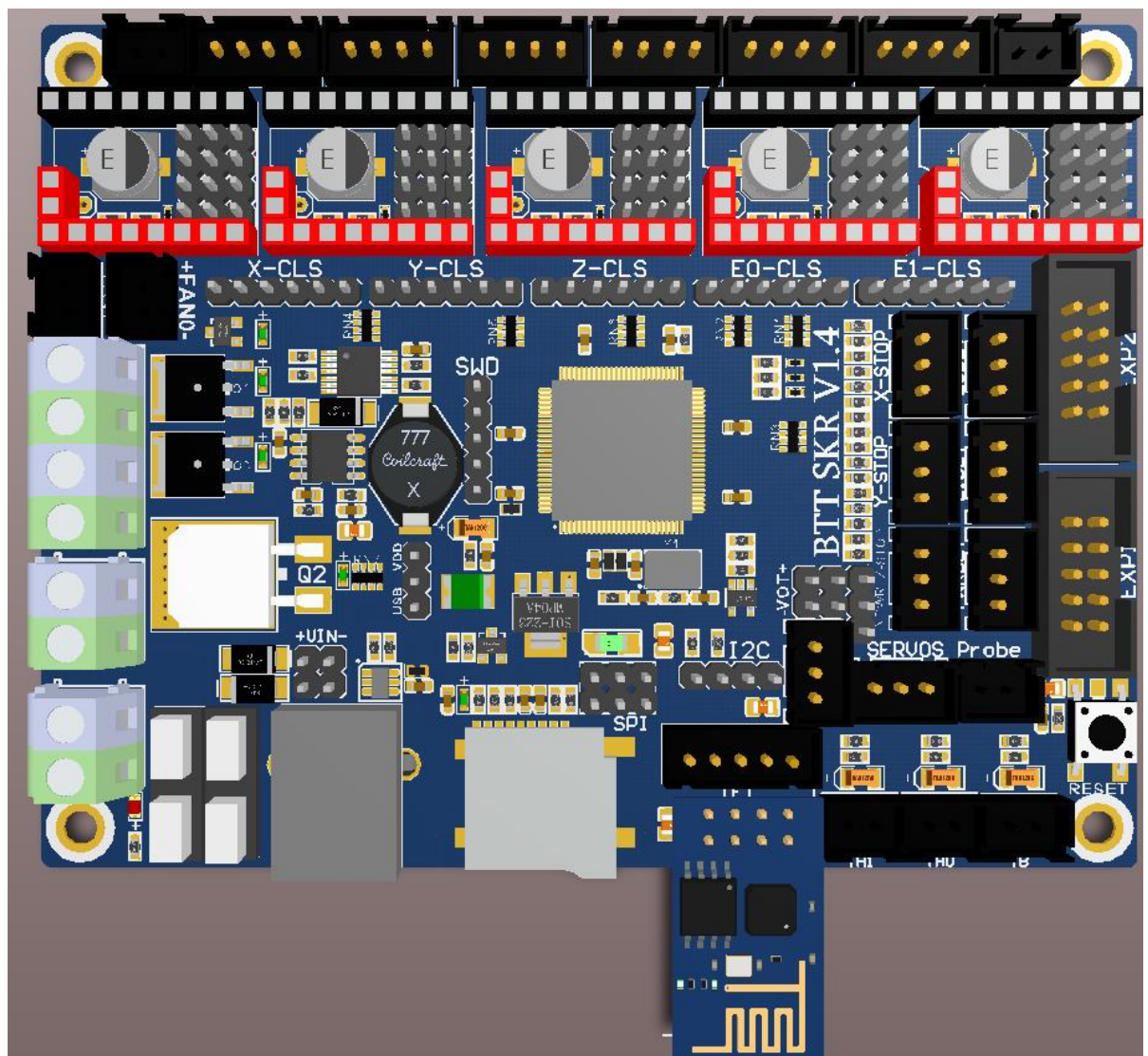

I .Product Introduction

BIGTREETECH SKR V1.4 motherboard is a 32-bit 3D printer motherboard optimized and upgraded by the 3D printing team of Shenzhen Big Tree Technology CO., LTD. for the deficiencies of V1.3 version, especially suitable for small and medium-sized printers.

1.SKR Motherboard Features::

- 1) Using 32-bit main frequency 100MHz ARM level Cortex-M3 series LPC1768 main control chip, the performance has been greatly improved;
- 2) Equipped with highly modular and open source firmware Marlin2.0, which is convenient for users to DIY and secondary development;
- 3) Using dedicated power chip M6130, support 12-24V power input;
- 4) Support 2.4, 2.8, 3.5 inch color touch screen, support LCD2004 screen, LCD12864 screen;
- 5) Upgrade and configure the firmware through SD card, which is simple, convenient and efficient;
- 6) The SPI and UART working mode driven by the TMC driver, also having the DIAG pin, which eliminates complex wiring process and can be used by simple unplugging jumper cap;
- 7) Support Resume Printing While Power Off, Filament Break Detection, Automatic Shutdown After Printing and so on;
- 8) High performance MOSFET tube, better heat dissipation effect;
- 9) Using removable fuse makes the replacement process easier;
- 10) Reserved extended port SERVOS and Probe to support BL Touch;;
- 11) Support RGB Neopixel light bar;
- 12) Use the power selection design to separate the USB power supply from the switch power supply, effectively avoiding the situation that the USB port of the computer is burnt out due to short circuit;
- 13) The special function interface uses the row needle with conspicuous color, which greatly reduces the error rate of wiring.
- 14) I2C, SPI and WIFI interfaces are reserved for convenience of DIY;
- 15) Closed-loop drive interface is reserved to reduce the trouble of plug-in switching module;
- 16) Double z-axis interface, eliminating the trouble of external drive expansion module;
- 17) The thermistor interface is protected by a bile capacitor pressurized resistor to enhance the resistance of the interface;
- 18) More fan interfaces: 1 way CNC fan, 3 way normally open fan;

Shenzhen Big Tree Technology CO.,LTD .
BIG TREE TECH

19) Plug-in external DC5V power supply module to supply power to TFT screen, BLtouch and Neopixel.

2. SKR Motherboard Parameters: :

Appearance size: 110*85mm

Mounting size: 102*76mm

Microprocessor: ARM Cortex-M3 CPU

Input voltage: DC12V-DC24V 5A-15A

Logic voltage: DC 3.3V

WIFI module: ESP-01S

Motor driver: Support TMC5161、TMC5160、TMC2209、TMC2225、TMC2208、TMC2130、ST820、LV8729、DRV8825、A4988 etc., independent external motor drive.

Driver working mode support: SPI、UART、STEP/DIR

Motor driver interface: X、Y、Z、E0、E1, 5 way (Each has a closed loop drive interface) up to 256 subdivisions

Temperature sensor interface: TH0, TH1, TB, 3 channel 100K NTC Temperature sensor interface: TH0, TH1, TB, 3 channel 100K NTC (thermal resistance)

Display: 2.4、2.8、3.5 inch TFT (Support dual mode screen)、LCD2004、LCD12864

PC communication interface: Square USB, easy to plug, communication baud rate of 115200

Expand the interface function support: Resume Printing While Power Off, Filament Break Detection, Automatic Shutdown After Printing, Automatic leveling, BL Touch

Support file format: G-code

Supported machine architecture: XYZ、delta、kossel、Ultimaker、corexy

Recommended software: Cura、Simplify3D、pronterface、Repetier-host、Makerware

II .SKR Motherboard Electricity:

After the SKR mainboard is powered up, the D5 red light in the lower left corner will go on, indicating normal power supply. The 5V SEL in the middle of the board is the power selection terminal;

1) When using USB to power the motherboard:



2) When using 12v-24v power supply:



III. SKR Motherboard and Computer Connection

SKR motherboard communicates with the computer through the [USB] interface. The computer needs to install the driver program first and then insert the motherboard into the computer to identify the port for data transmission. Without installing the driver, it is easy for the computer to fail to recognize the USB port.

Using the Marlin2.0 firmware, follow the tutorial for installation:

tutorial: <https://www.dropbox.com/s/ppjflhf3j5yzh2/MarlinV2.0%20SKRV1.1%20instruction.docx?dl=0>

driver: https://www.dropbox.com/s/a0k5idjmf4fn82f/lpc176x_usb_driver.inf?dl=0



IV. SKR Motherboard and Interface Instruction

1. SKR Motherboard Size Diagram

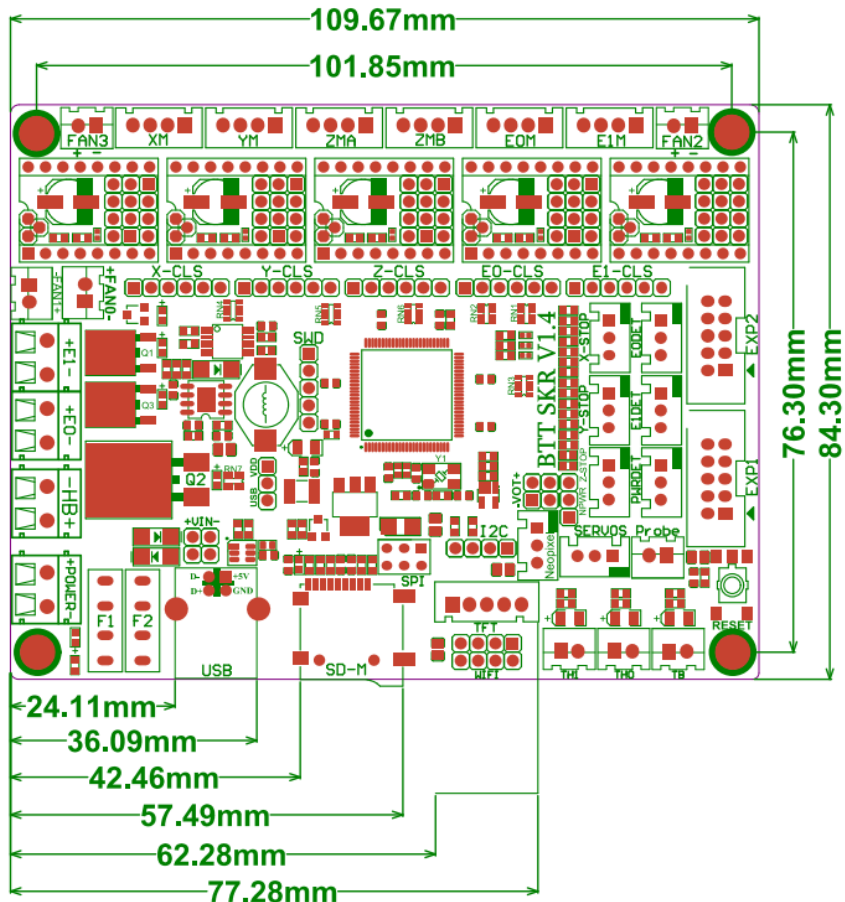

Shenzhen Big Tree Technology CO.,LTD .
BIG TREE TECH

2. SKR Motherboard Wiring Diagram

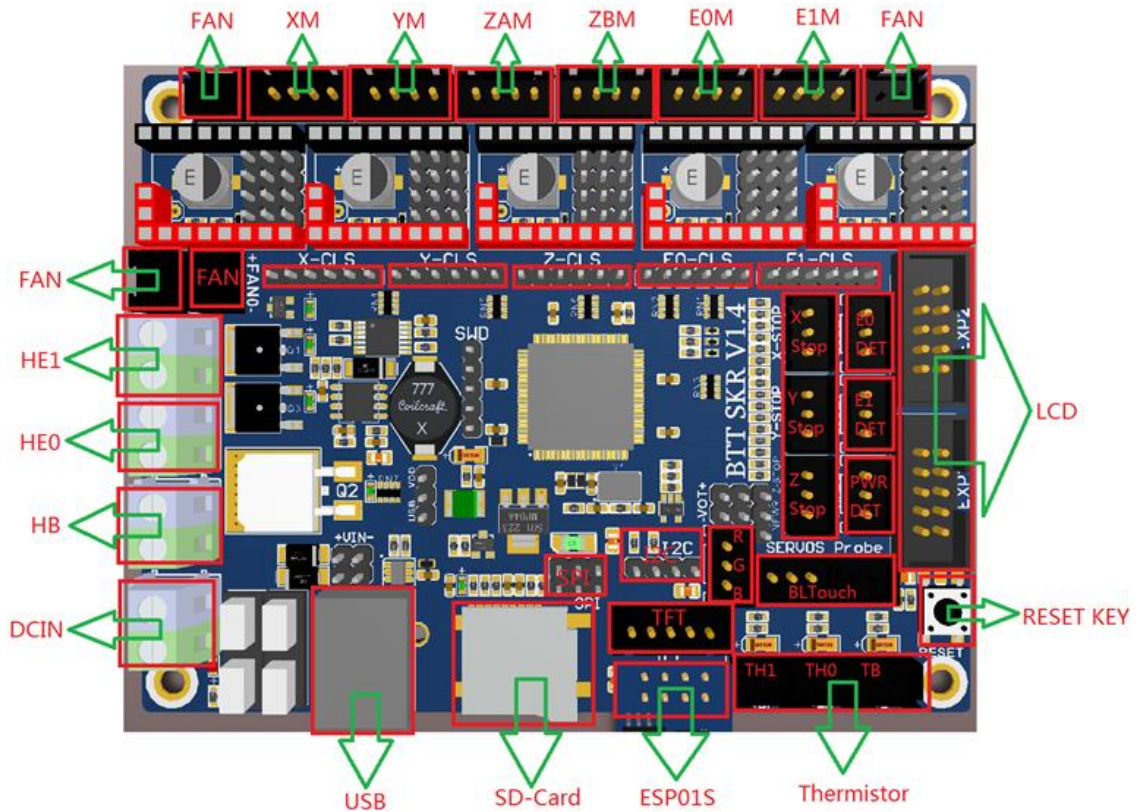

3. Drive Mode and Selection Method:

- ① Common STEP/DIR mode: (for example: A4988, DRV8825, LV8729, ST820, etc.) select the short circuit cap to connect MS0-MS2 according to the driver subdivision table.

Driver-STEP/DIR MODE

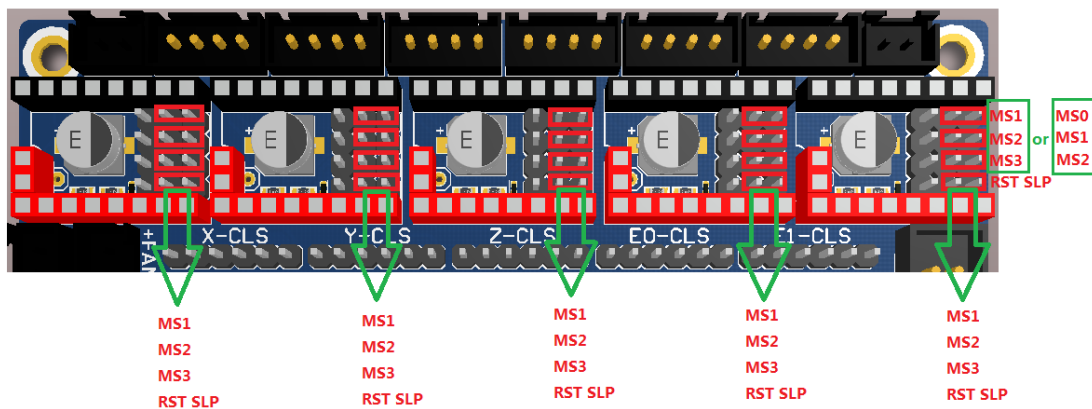

Note: if you are using A4988 or DRV8825 driver, you must connect RST and SLP with jumper cap.

Shenzhen Big Tree Technology CO.,LTD .
BIG TREE TECH

Driver Chip	MS1	MS2	MS3	Subdivision	Excitation Mode
A4988 Maximum 16 subdivision 35V 2A	L	L	L	Full Step	2 Phase
	H	L	L	1/2	1-2 Phase
	L	H	L	1/4	W1-2 Phase
	H	H	L	1/8	2W1-2 Phase
	H	H	H	1/16	4W1-2 Phase
Driving current calculation formula Rs=0.1Ω	$I_{max} = \frac{V_{ref}}{(8 * R_s)}$				

Driver Chip	MODE2	MODE1	MODE0	Subdivision	Excitation Mode
DRV8825 Maximum 32 subdivision 8.2V-45V 2.5A at 24V T=25°C	L	L	L	Full Step	2 Phase
	L	L	H	1/2	1-2 Phase
	L	H	L	1/4	W1-2 Phase
	L	H	H	1/8	
	H	L	L	1/16	
	H	L	H	1/32	
	H	H	L	1/32	
Driving current calculation formula Rs=0.1Ω	$I_{CHOP} = \frac{V_{REFX}}{5 \cdot R_{ISENSE}}$				

Driver Chip	MD3	MD2	MD1	Subdivision	Excitation Mode
LV8729 Maximum 128 subdivision 36V 1.8A	L	L	L	Full Step	2 Phase
	L	L	H	1/2	1-2 Phase
	L	H	L	1/4	W1-2 Phase
	L	H	H	1/8	2W1-2 Phase
	H	L	L	1/16	4W1-2 Phase
	H	L	H	1/32	8W1-2 Phase
	H	H	L	1/64	16W1-2 Phase
	H	H	H	1/128	32W1-2 Phase
Driving current calculation formula Rs=0.22Ω	$I_{OUT} = (V_{REF} / 5) / R_{F1}$				

Shenzhen Big Tree Technology CO.,LTD .
BIG TREE TECH

Driver Chip	MS3	MS2	MS1	Subdivision
ST820 Maximum 256 subdivision 45V 1.5A	L	L	L	Full Step
	L	L	H	1/2
	L	H	L	1/4
	L	H	H	1/8
	H	L	L	1/16
	H	L	H	1/32
	H	H	L	1/128
	H	H	H	1/256
Driving current calculation formula Rs=0.15Ω	$I_{\text{peak}} = \frac{V_{\text{REF}} * V_{\text{DD}}}{5 * R_S}$			

- ② TMC Driver-UART Mode: (eg: TMC2208, TMC2209, TMC2225, etc.) Each axis uses a shorting cap to connect the red frame in the figure. The subdivision and drive current are set by firmware.

TMC Driver-UART MODE

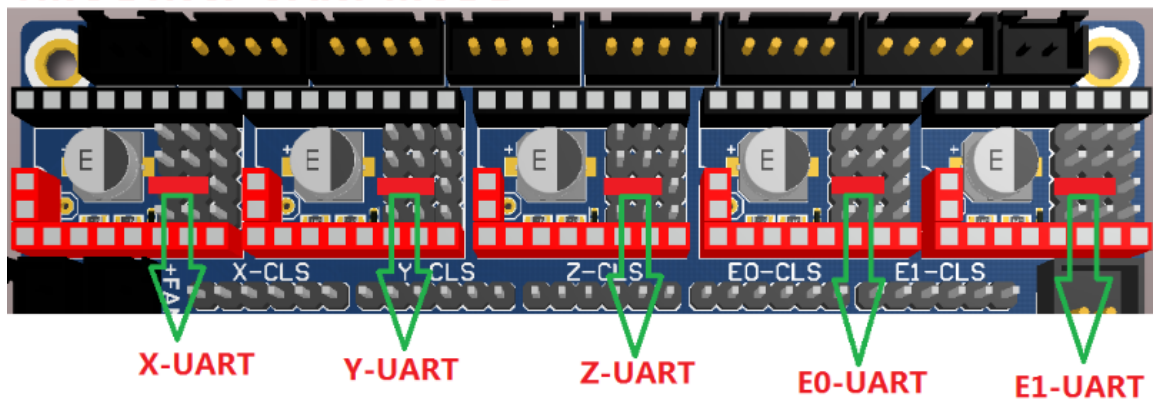

Note: When using the TMC2209, if you don't use the stallguard function, you need to cut off the DIAG pin on the driver so that the mechanical switch can work normally. The operation method is as shown below:

① Before cutting ↓

② After cutting ↓

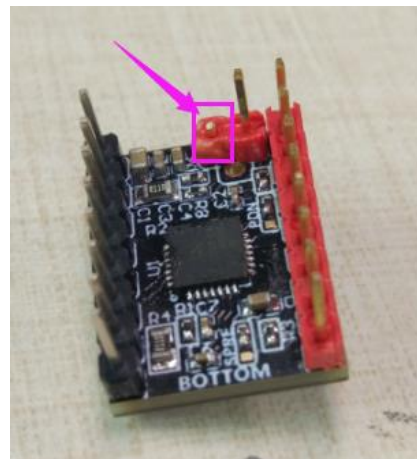
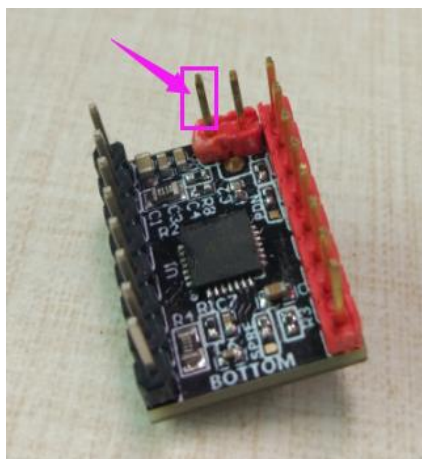

Shenzhen Big Tree Technology CO.,LTD . BIG TREE TECH

Note: This function pin needs to be trimmed only when the blocking detection function is not used.

③ TMCDriver-SPI Mode: (such as: TMC2130, TMC5160, TMC5161, etc.)
Each axis uses four shorting caps to connect the red frame position in the figure. The subdivision and drive current are set by firmware.

TMC Driver-SPI MODE

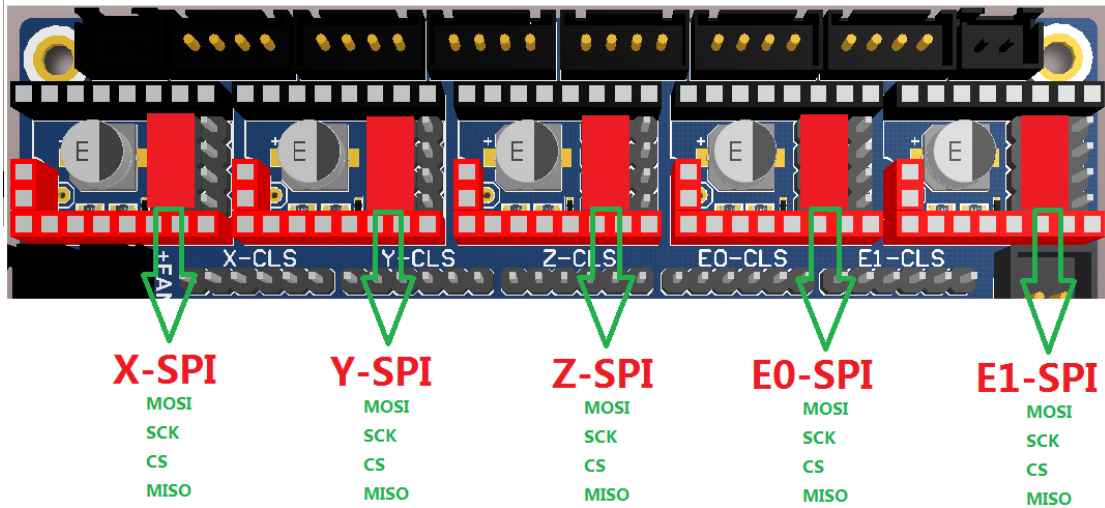

4、The connection of SKR V1.4 and BL touch:

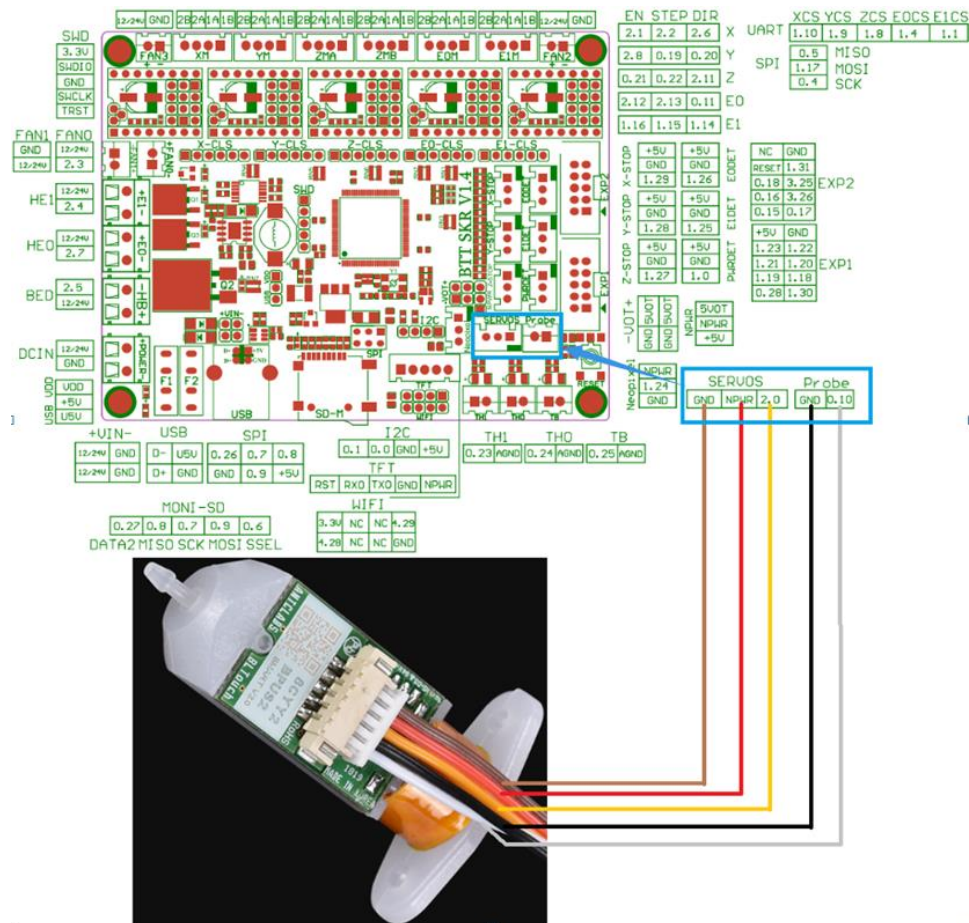

Shenzhen Big Tree Technology CO.,LTD .
BIG TREE TECH

5、The connection of SKR V1.4 and Automatic Shutdown After Printing Module (Relay V1.2) :

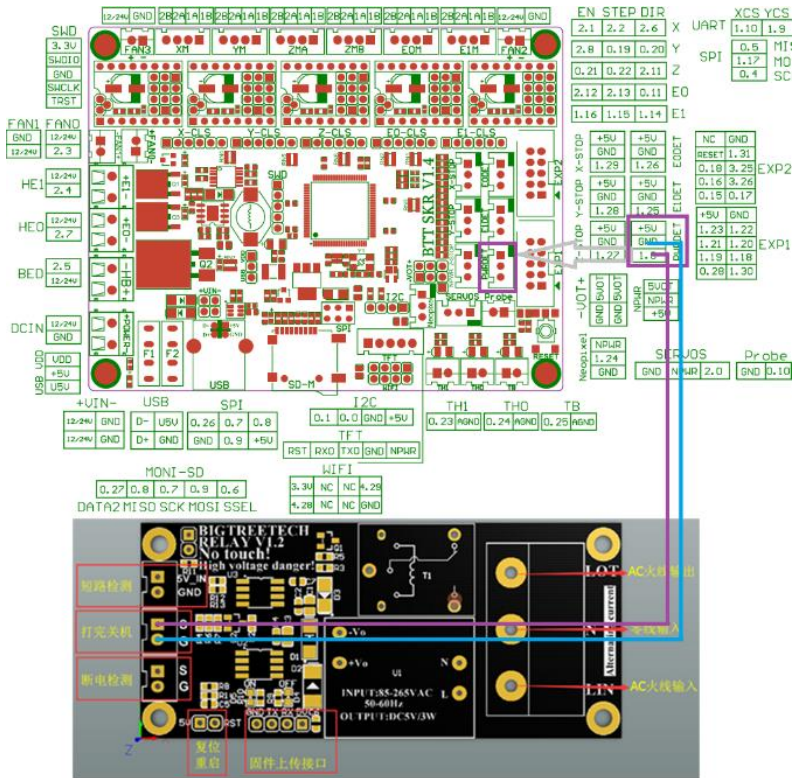

6、The connection of SKR V1.4 and Resume Printing While Power Off Module (UPS 24V V1.0) :

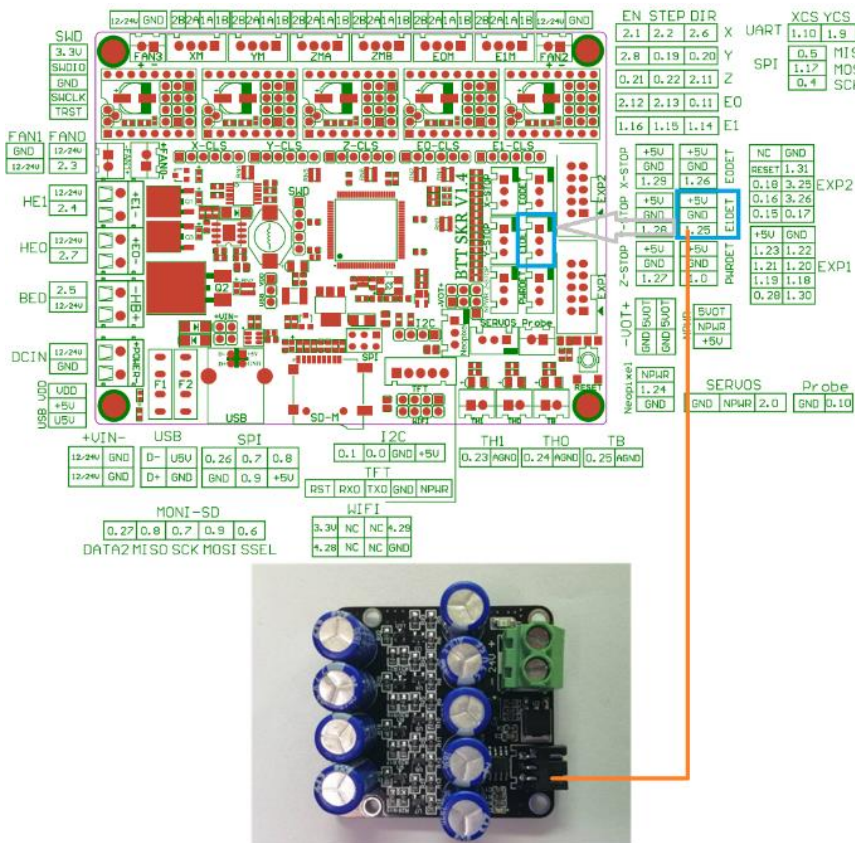

Shenzhen Big Tree Technology CO.,LTD . BIG TREE TECH

7、 The connection of SKR V1.4 and Raspberry Pi:

No need to connect V+

Raspberry Pi 3 and SKR V1.4 both with 3.3V logic.

PI 3B+ @ GPIO connector TXD0 - RXD0 - GND (8-0-10)

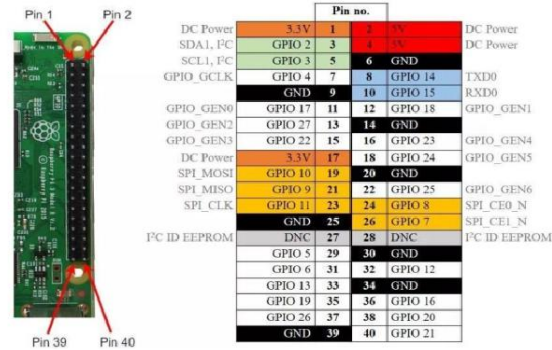

SKR V1.4 @ TFT connector TX - Rx - GND

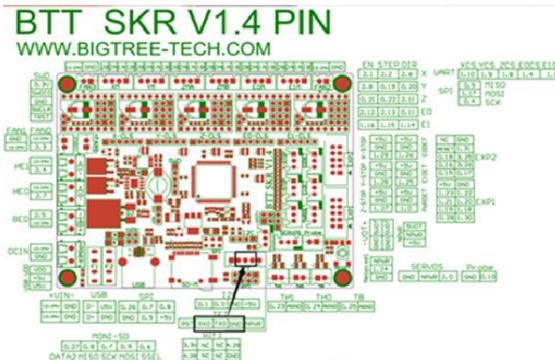

8、 The connection of SKR V1.4 and closed loop driver:

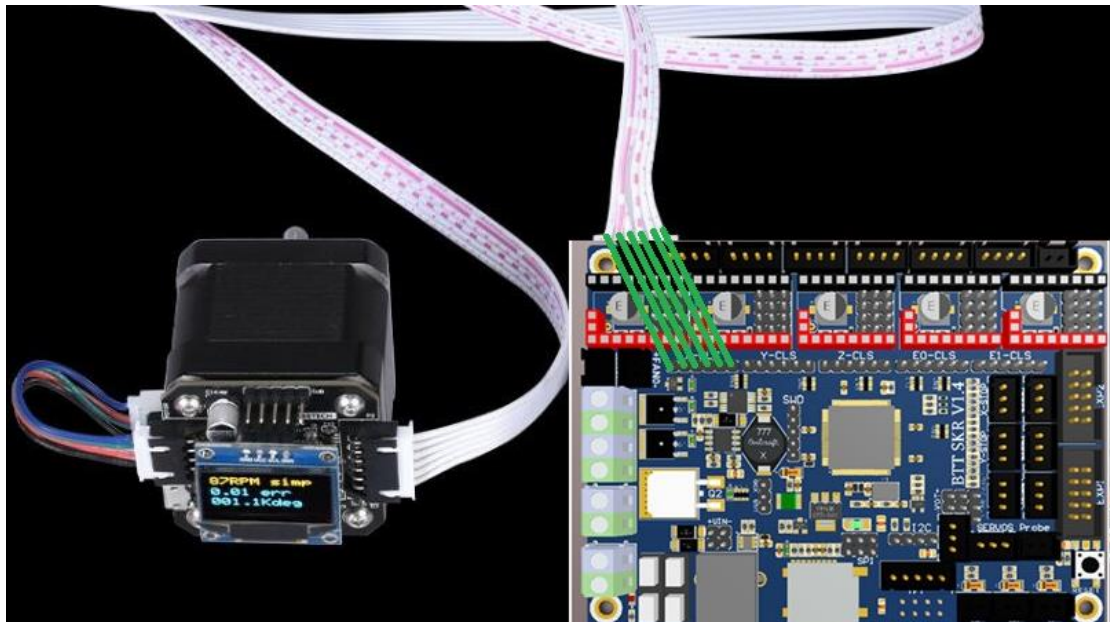

V. The firmware description of SKR motherboard

The factory motherboard is installed equipped with firmware for testing (model I3), which can be used directly or changed according to your own needs.

1. The Firmware Acquisition Method of SKR Motherboard:

Obtain by Ask customer service or technical personnel;

Download at our Company Open source website:

<https://github.com/bigtreotech>

2. Marlin2.0 Firmware update method

After downloading our open source Marlin2.0 firmware, use Visual Studio Code to open the project to compile, then find the firmware.bin file, copy it to the SD card, and then reset the motherboard. For detailed steps, please refer to the tutorial:

<https://www.dropbox.com/s/pjfflhf3j5yzh2/MarlinV2.0%20SKRV1.1%20instruction.docx?dl=0>

VI. Notes:

1. The motherboard 5V SEL must connect VDD and +5V two pins before printing (that is, 12v-24v power supply must be provided to the motherboard for printing);

2. The power of the hot bed connected to the motherboard must be less than or equal to 144W (that is, the thermal bed resistance is greater than 1 Ω). If you want to use a high-power hot bed, you must connect an external hot-bed power expansion board;

3. Firmware file names in SD card cannot be changed (including letter case);

4. The wiring process and plug-in drive process must be

Shenzhen Big Tree Technology CO.,LTD .
BIG TREE TECH

carried out under the premise of power failure. The power can be put on after checking the correct connection of the line and the correct insertion of the drive, so as to prevent the wrong connection line from burning the motherboard and driver and causing unnecessary losses;

5. To replace the configuration file, please backup the factory configuration file to record the pin number of each part of the chip, and then change the new configuration file!

If you encounter other problems, please contact us. We will definitely answer your questions patiently. If you have any good suggestions on our products, please give us feedback. We will consider them seriously. Thank you for choosing **BIGTREETECH** products!